

SPECIFIKATIONER

LJUNGBY L11

STEG V MOTOR



Foto: Lars Malm 2019_01
790036-17 Rev.1



SUPERIOR PERFORMANCE

- LÅGA TOTALKOSTNADER ■ DRIFTSÄKER OCH SERVICEVÄNLIG
- LÖSNINGAR EFTER DINA BEHOV ■ UNIKT LASTAGGREGAT
- KRAFTFULLA MILJÖMOTORER ■ MARKNADENS LÄGSTA LJUDNIVÅ





SPECIFIKATIONER | LJUNGBY L11

S = standard

0 = tillval

DRIVLINA

Motor	Sisu 66 LFTN
Max effekt [kW/ hk]	151/205
Max vridmoment [Nm]	940
Transmission	ZF Ergopower WG160
Framaxel	ZF MTL 3075
Bakaxel	ZF MTL 3075
Automatisk diffbroms bak	S
Automatisk/manuel I diffbroms fram	S
Tvåkrets hydraulisk färdbroms	S
Hydraulisk parkeringsbroms	S
Lock-up transmission	0
Vändbar fläkt	0

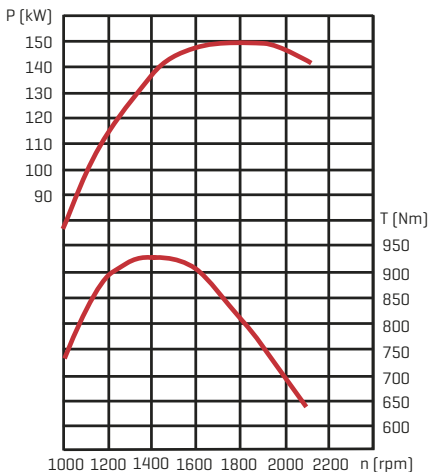

P = effekt T = vridmoment
n = varvtal

KRAFT OCH VIKT

Brytkraft, standardskopa [kN]	95
Tipplast [kg]	0° 8100
	40° 6950
	45° 6550
Tjänstevikt [ton]	10,9-11,5
Standardskopa [m³]	2,1
Lättmaterialskopa [m³]	5,0
Timmergrip [m²]	1,6

HYDRAULSYSTEM

Hydraulpump	Parker
Flöde [l/min vid 2100 rpm]	220
Tryck [bar]	250
Lyftcylinder [mm]	56/110
Slag lyftcylinder [mm]	850
Tiltcylinder [mm]	56/100
Slag tiltcylinder [mm]	895
Hydraulkyllning	S

STYRSYSTEM

Styrvinkel [grader]	45
Styrcylinder [mm]	40/70
Slag styrcylinder [mm]	557
Pendling bakaxel [grader]	+/-15

DIMENSIONER

A	7070
B	3000
C	1555
D	440
E	4070
F	2745
G	1075
H	3280
I	2475
J	2620
R1	4920
R2	5515

ELSYSTEM

Batteri	2 x 12 V, 120 A
Generator	100 A

RYMDUPPGIFTER

Kylsystem [l]	30
Motor [l]	29
Hydraulsystem [l]	175
Bränsletank [l]	210
Ad Blue tank [l]	60

Mått refererar till figuren nedan [mm]

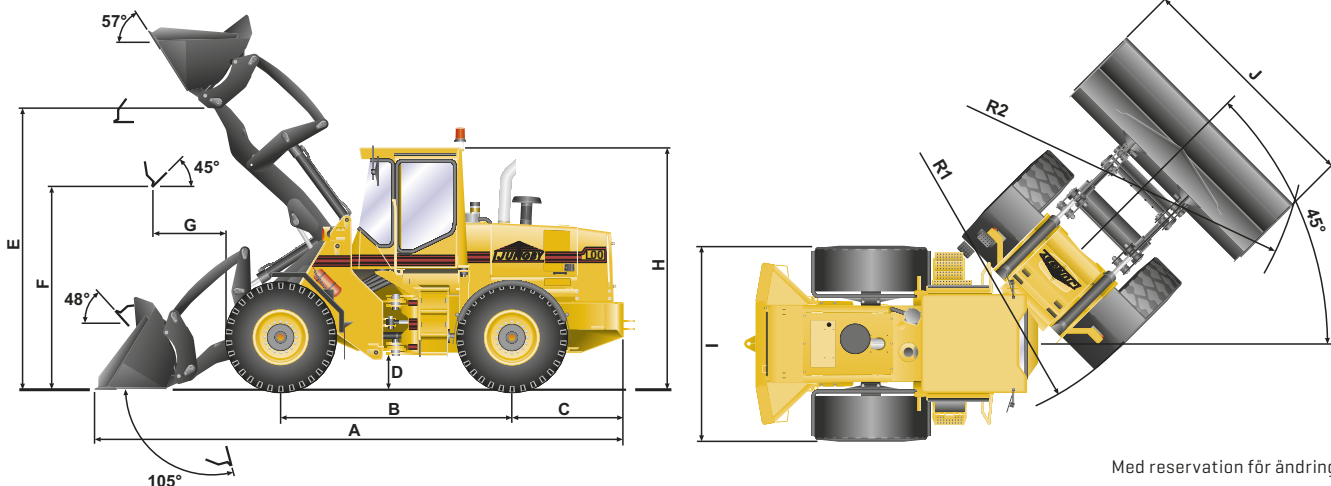

Med reservation för ändringar