

SPECIFIKATIONER

LJUNGBY L13

STEG V MOTOR



Foto: Lars Malmström 019_01
750036-13 Rev.1



SUPERIOR PERFORMANCE

- LÅGA TOTALKOSTNADER ■ DRIFTSÄKER OCH SERVICEVÄNLIG
- LÖSNINGAR EFTER DINA BEHOV ■ UNIKT LASTAGGREGAT
- KRAFTFULLA MILJÖMOTORER ■ MARKNADENS LÄGSTA LJUDNIVÅ





SPECIFIKATIONER | LJUNGBY L13

S = standard

O = tillval

DRIVLINA

Motor	Sisu 66 LFTN
Max effekt [kW/ hk]	157/213
Max vridmoment [Nm]	945
Transmission	ZF Ergopower WG190
Framaxel	ZF MTL 3085
Bakaxel	ZF MTL 3085
Automatisk diffbroms bak	S
Automatisk/manuel I diffbroms fram	S
Tvåkrets hydraulisk färdbroms	S
Hydraulisk parkeringsbroms	S
Lock-up transmission	O
Vändbar fläkt	O

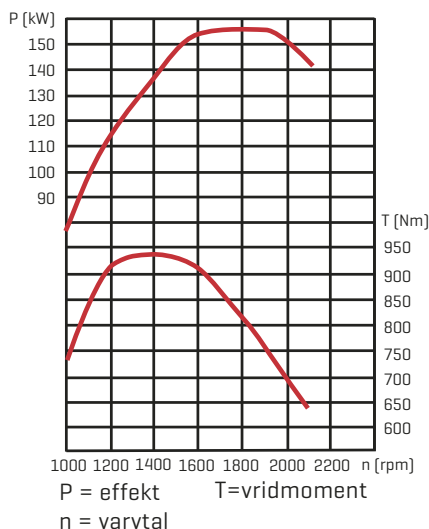

KRAFT OCH VIKT

Brytkraft, standardskopa [kN]	110
Tipplast [kg]	0° 9300
	40° 8000
	45° 7700
Tjänstevikt [ton]	12,8-13,6
Standardskopa [m³]	2,4
Lättmaterialskopa [m³]	6,0
Timmergrip [m²]	1,6

HYDRAULSYSTEM

Hydraulpump	Parker
Flöde [l/min vid 2100 rpm]	304
Tryck [bar]	240
Lyftcylinder [mm]	60/115
Slag lyftcylinder [mm]	925
Tiltcylinder [mm]	60/115
Slag tiltcylinder [mm]	895
Hydraulkyllning	S

STYRSYSTEM

Styrvinkel [grader]	45
Styrcylinder [mm]	40/70
Slag styrcylinder [mm]	557
Pendling bakaxel [grader]	+/-15

HJUL

Radialdäck	S
Dimension	20,5R25

DIMENSIONER

A	7260
B	3100
C	1535
D	430
E	4180
F	2660
G	1160
H	3300
I	2530
J	2630
R1	4980
R2	5570

ELSYSTEM

Batteri	2 x 12 V, 120 A
Generator	100 A

RYMDUPPGIFTER

Kylsystem [l]	30
Motor [l]	29
Hydraulsystem [l]	195
Bränsletank [l]	210
Ad Blue tank [l]	60

Mått refererar till figuren nedan [mm]

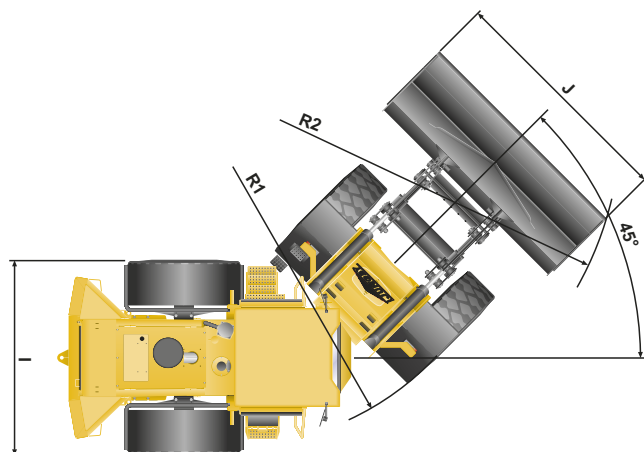
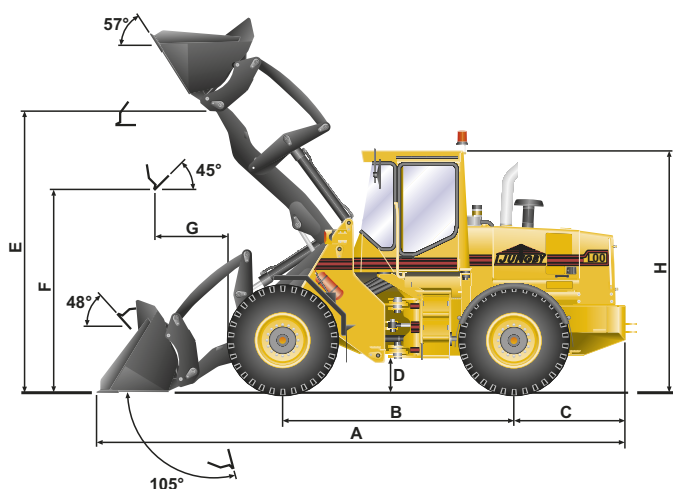

Med reservation för ändringar