

SPECIFIKATIONER

# LJUNGBY L15

STEG V MOTOR OCH LOCK-UP 157kW



Foto: Lars Malm ©2019, 01  
790036-23 Rev.1



SUPERIOR PERFORMANCE

- LÅGA TOTALKOSTNADER ■ DRIFTSÄKER OCH SERVICEVÄNLIG
- LÖSNINGAR EFTER DINA BEHOV ■ UNIKT LASTAGGREGAT
- KRAFTFULLA MILJÖMOTORER ■ MARKNADENS LÄGSTA LJUDNIVÅ





## SPECIFIKATIONER | LJUNGBY L15

S = standard

O = tillval

### DRIVLINA

Motor	Sisu 66 LFTN
Max effekt [kW/ hk]	157/213
Max vridmoment [ Nm]	945
Transmission	ZF Ergopower WG210
Framaxel	ZF MTL 3085
Bakaxel	ZF MTL 3085
Automatisk diffbroms bak	S
Automatisk/manuel I diffbroms fram	S
Tvåkrets hydraulisk färdbroms	S
Hydraulisk parkeringsbroms	S
Lock-up transmission	S
Vändbar fläkt	O

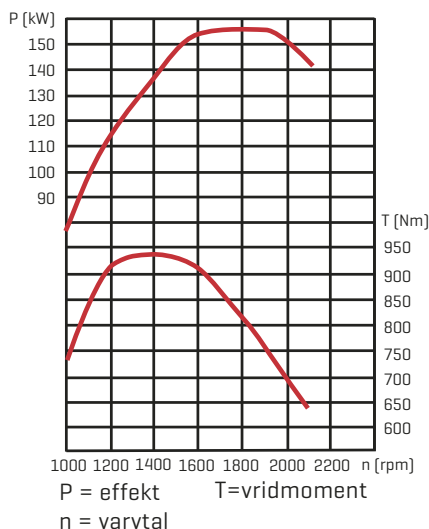

### HYDRAULSYSTEM

Hydraulpump	Parker
Flöde [l/min vid 2100 rpm]	304
Tryck [bar]	250
Lyftcylinder [mm]	60/115
Slag lyftcylinder [mm]	925
Tiltcylinder [mm]	60/115
Slag tiltcylinder [mm]	895
Hydraulkyllning	S

### STYRSYSTEM

Styrvinkel [grader]	45
Styrcylinder [mm]	40/80
Slag styrcylinder [mm]	557
Pendling bakaxel [grader]	+/-15

### ELSYSTEM

Batteri	2 x 12 V, 120 A
Generator	100 A

### RYMDUPPGIFTER

Kylsystem [l]	30
Motor [l]	29
Hydraulsystem [l]	195
Bränsletank [l]	210
Ad Blue tank [l]	60

### KRAFT OCH VIKT

Brytkraft, standardskopa [kN]	120
Tipplast [kg]	0° 10900
	40° 9350
	45° 9100
Tjänstevikt [ton]	14,5-16,0
Standardskopa [m³]	2,7
Lättmaterialskopa [m³]	8,0
Timmergrip [m²]	2,0

### HJUL

Radialdäck	S
Dimension	20,5R25

### DIMENSIONER

A	7400
B	3100
C	1635
D	430
E	4180
F	2660
G	1160
H	3310
I	2535
J	2800
R1	5090
R2	5950

Mått refererar till figuren nedan [mm]

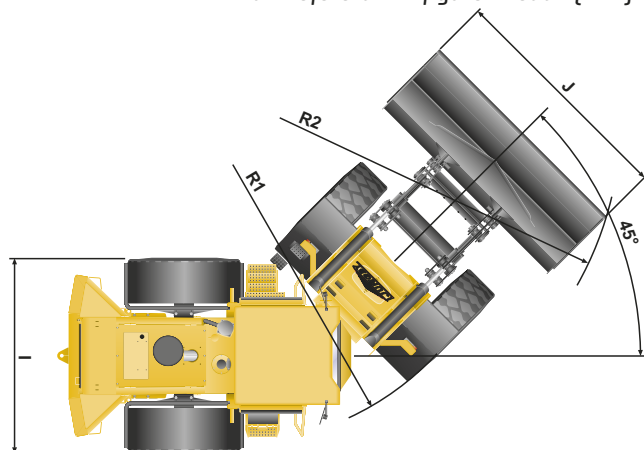
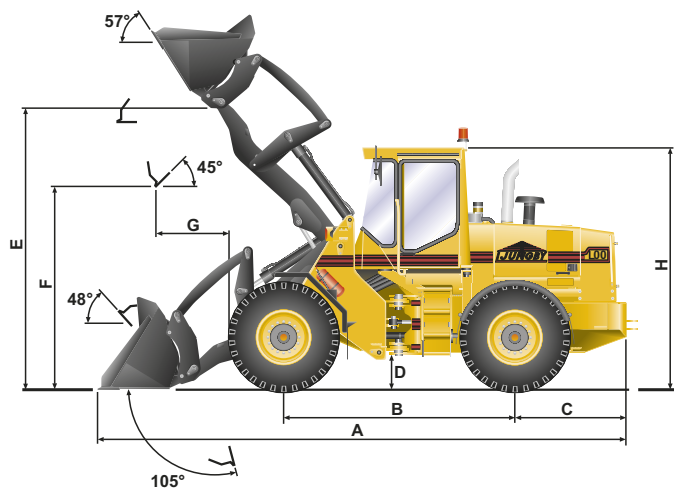

Med reservation för ändringar