

SPECIFICATIONS

# LJUNGBY L11

TIER 5 ENGINE



Foto: Lars Malm 2019\_01  
790036-403 Rev.1



SUPERIOR PERFORMANCE

- LOW TOTAL COSTS ■ SOLUTIONS ACCORDING TO YOUR NEEDS
- UNIQUE LOAD UNIT ■ POWERFUL ENVIRONMENTAL ENGINES
- RELIABLE AND SERVICE FRIENDLY ■ LOWEST NOISE LEVEL ON THE MARKET





## SPECIFICATIONS

## LJUNGBY L11

S = standard

O = optional

### DRIVE LINE

Engine	Sisu 66 LFTN
Max power [kW/hp]	151/205
Max torque [Nm]	940
Transmission	ZF Ergopower WG160
Front axle	ZF MTL 3075
Rear axle	ZF MTL 3075
Automatic limited slip rear	S
Automatic/manuall imited slip front	S
Dual-circuit hydraulic foot brake	S
Hydraulic operated parking brake	S
Lock-up transmission	O
Reversible fan	O

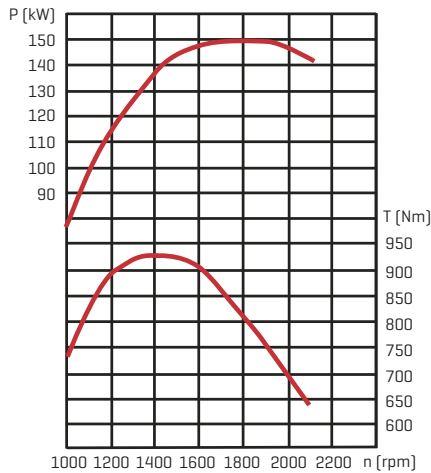

P = power T=torque  
n = number of revolutions

### POWER AND WEIGHT

Breakout force [kN]	95
Tipping load [kg]	0° 8100
	40° 6950
	45° 6550
Operating weight [tons]	10,9-11,5
Standard bucket [m3 ]	2,1
Light material bucket [m3 ]	5,0
Timber grapple [m2]	1,6

### WHEELS

Radial tyres	S
Dimensions	20,5R25

### HYDRAULIC SYSTEM

Hydraulic pump	Parker
Flow [l/min at 2100 rpm]	220
Pressure [bar]	250
Lift cylinder [mm]	56/110
Lift cylinder stroke [mm]	850
Tilt cylinder [mm]	56/100
Tilt cylinder stroke [mm]	895
Hydraulic cooling	S

### STEERING SYSTEM

Steering angle [degrees]	45
Steering cylinder [mm]	40/70
Steering cylinder stroke [mm]	557
Oscillating rear axle [degrees]	+/-15

### DIMENSIONS

A	7070
B	3000
C	1555
D	440
E	4070
F	2745
G	1075
H	3280
I	2475
J	2620
R1	4920
R2	5515

### ELECTRICAL SYSTEM

Battery	2 x 12 V, 120 A
Alternator	100 A

### CAPACITY INFORMATION

Cooling system [l]	30
Engine [l]	29
Hydraulic system [l]	175
Fuel tank [l]	210
Ad Blue tank [l]	60

Dimensions refer to figure below [mm]

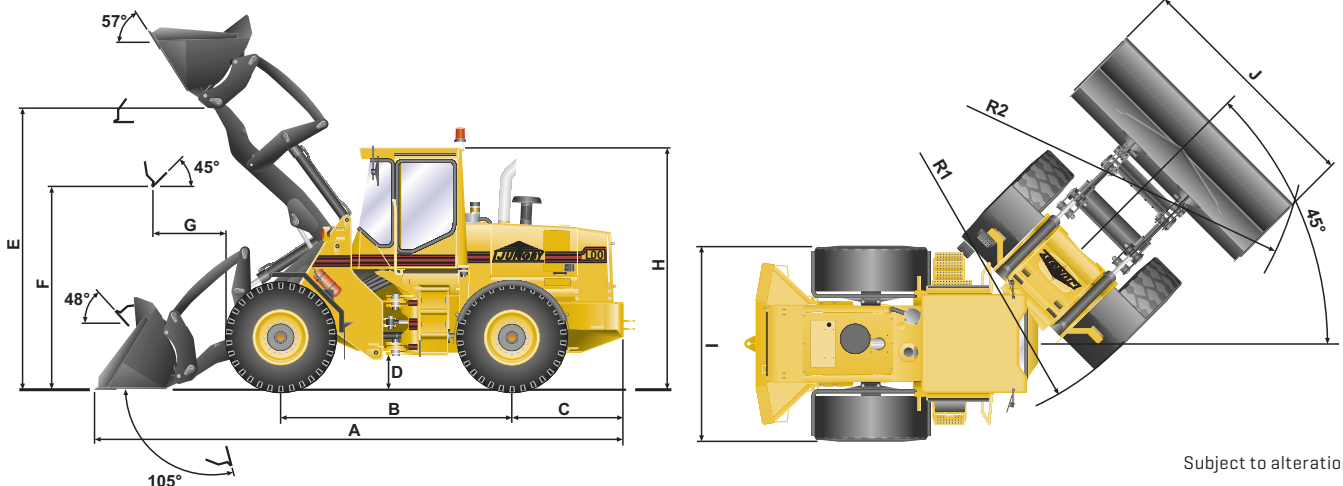

Subject to alteration